

The VISIONIS VIS-1200D-LED is designed to keep your double doors secure with a 1200 lbs holding force per door (2,400 lbs total).

Whether you're securing a retail store, office, or commercial building, this lock provides strong and reliable protection, preventing unauthorized access with a firm electromagnetic hold.

Features

- Ideal for double swing doors
- Dual voltage selectable (12 VDC or 24 VDC)
- Low current consumption
- Reliable holding force
- Hall effect sensor monitoring output
- Green/Red LED indication for EM lock status
- Durable and silence operation
- Cosmeticized anodized aluminum casing
- Surge & spike protection PCB
- Anti-tamper jam nuts
- Anti residual magnetism kick off button

| Model No. | VIS-1200D-LED |
|-----------------------------|--|
| Usage Environment | Indoor only |
| Input Voltage | DC 12V / 24V |
| Input Current | 12V 500 mA ×2 (±5%) ; 24V 265 mA ×2 (±5%) |
| Hall Effect Contact | SPDT, rated 1 A @ 24 VDC |
| Function | Fail Safe (Normally Close) = Unlocked when the power is OFF |
| Holding Force | Up to 1200 lbs x 2 (545 kg x 2) |
| Product Dimensions | Magnet - 532L x 67W x 39H mm - (21L x 2.63W x 1.54H in) Armature - 185L x 61W x 16.5H mm - (7.28L x 2.40W x 0.65H in) |
| Weight | 9.4 kg (±1%) - 20.72 lbs |
| Anti-Rust Surface Treatment | Blue Zinc Plating |
| Operating Temperature | 0 °C ~ 55 °C (32 °F ~ 131 °F) |
| Operating Humidity | 0 ~ 95% (non condensing) |
| Certifications & Compliance | CE |
| Suitable For | Wooden door, glass door, metal door, fireproof door |

Need assistance? Contact Us: 1-800-340-0727 // support@visionistech.com // www.visionistech.com

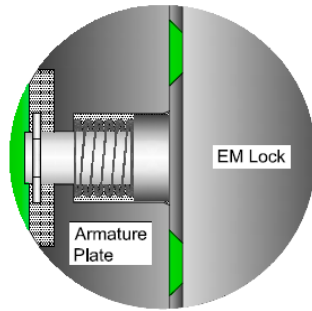

EM Lock Energized

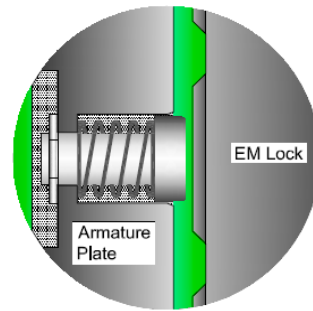

EM Lock De-energized

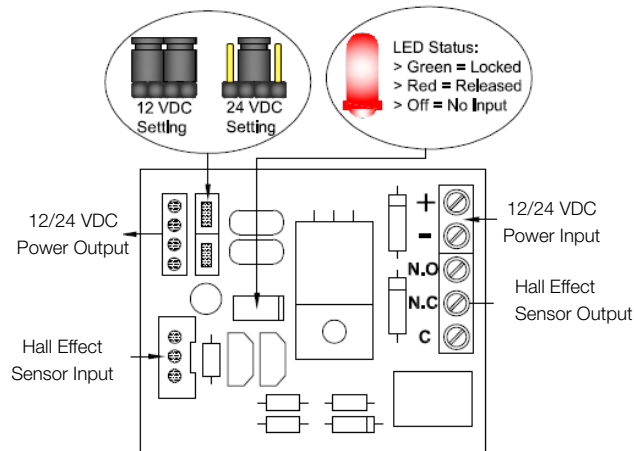

IMPORTANT!

Set the jumper position according to the power input before switching on the power.

Need assistance? Contact Us: 1-800-340-0727 // support@visionistech.com // www.visionistech.com