

**Installation User Guide
(Indoor Models)**

Scan the QR code to watch
the installation video

<https://youtu.be/e-q0HVZLGK0>

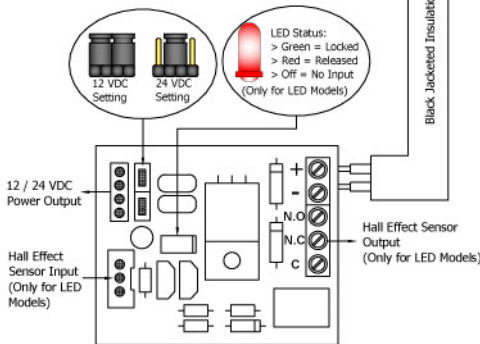
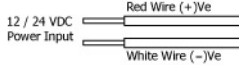
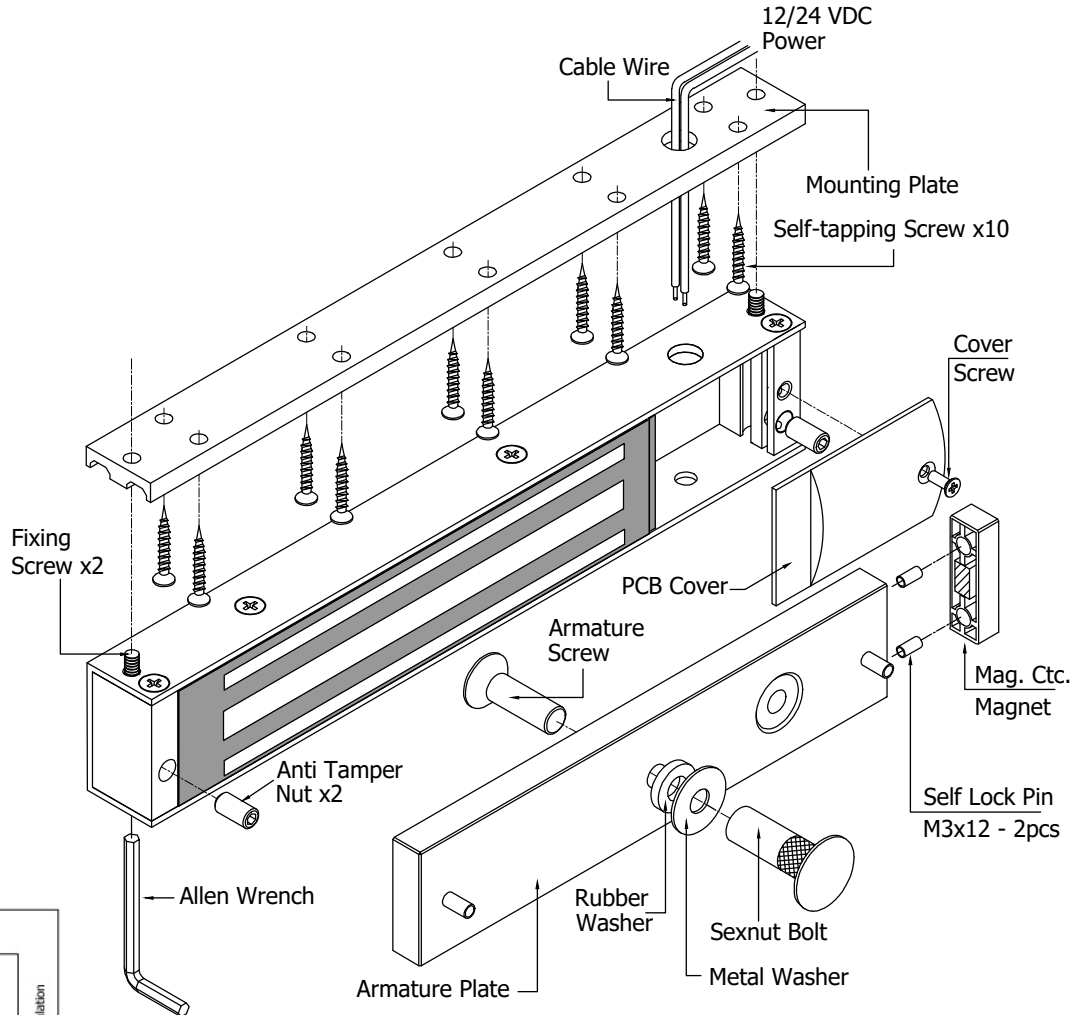
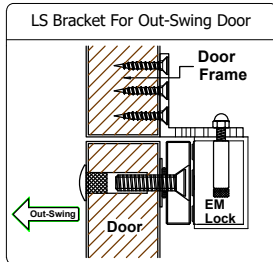
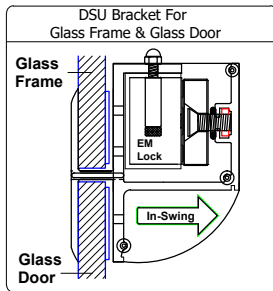
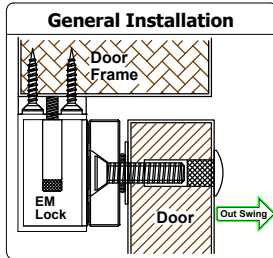

IMPORTANT!

Set the jumper position according to the power input correctly before switch ON the power

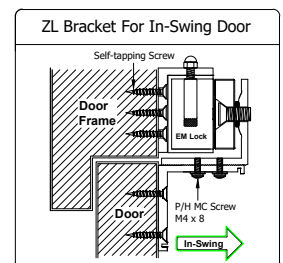
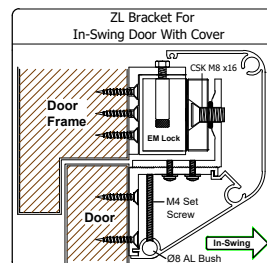
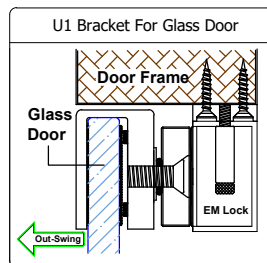

Need assistance? Contact Us: 1-800-340-0727 // support@visionistech.com // www.visionistech.com

General Installation Steps & Maintenance

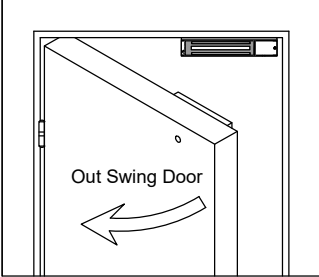

Out Swing Door

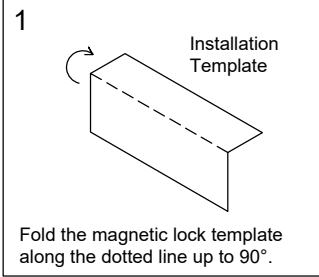
- 

1 Installation Template

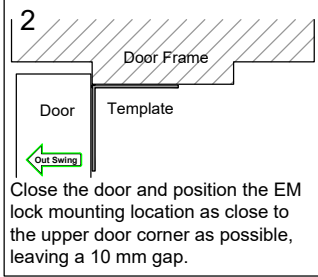
Fold the magnetic lock template along the dotted line up to 90°.
- 

2 Door Frame
Door
Template

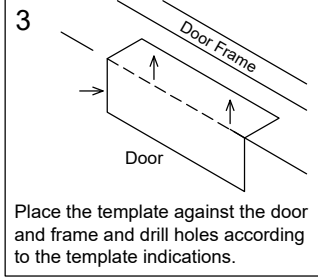
Close the door and position the EM lock mounting location as close to the upper door corner as possible, leaving a 10 mm gap.
- 

3 Door Frame
Door

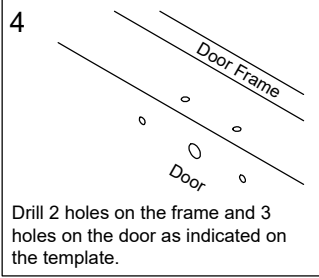
Place the template against the door and frame and drill holes according to the template indications.
- 

4 Door Frame
Door

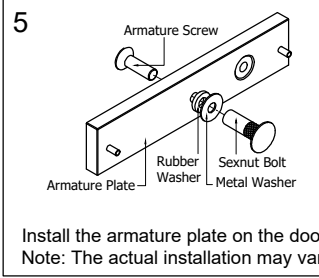
Drill 2 holes on the frame and 3 holes on the door as indicated on the template.
- 

5 Armature Screw
Armature Plate
Rubber Washer
Sextnut Bolt
Metal Washer

Wooden Door
Door

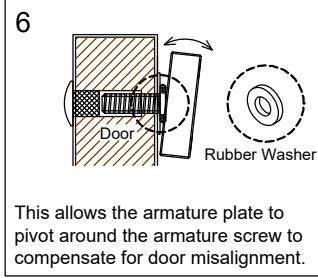
Install the armature plate on the door.
Note: The actual installation may vary depending on the door type.
- 

6 Door
Rubber Washer

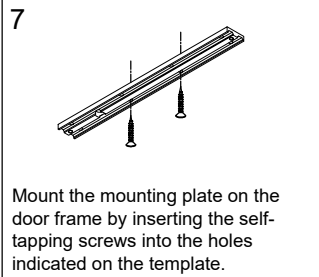
This allows the armature plate to pivot around the armature screw to compensate for door misalignment.
- 

7

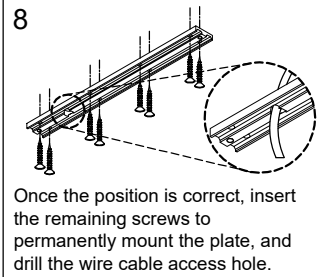
Mount the mounting plate on the door frame by inserting the self-tapping screws into the holes indicated on the template.
- 

8

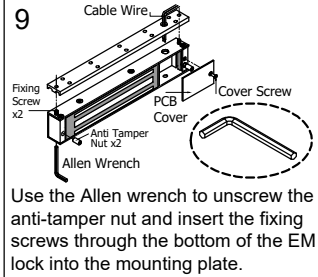
Once the position is correct, insert the remaining screws to permanently mount the plate, and drill the wire cable access hole.
- 

9 Cable Wire
Fixing Screw x2
Anti-Tamper Nut x2
Allen Wrench
PCB Cover
Cover Screw

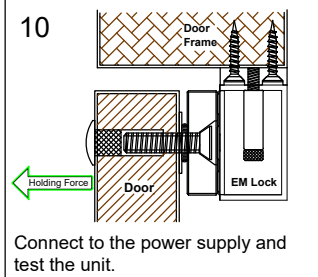
Use the Allen wrench to unscrew the anti-tamper nut and insert the fixing screws through the bottom of the EM lock into the mounting plate.
- 

10 Door Frame
Door
EM Lock

Connect to the power supply and test the unit.

ZL Bracket for Swing-In Door Installation Guide

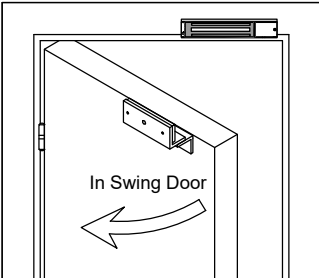

In Swing Door

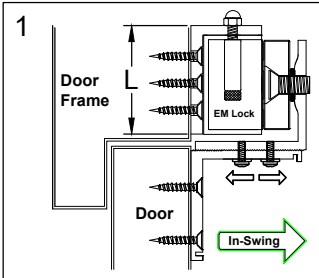
- 

1 Door Frame
Door
EM Lock
In-Swing

The door frame minimum height value "L" is required to accommodate the bracket model.

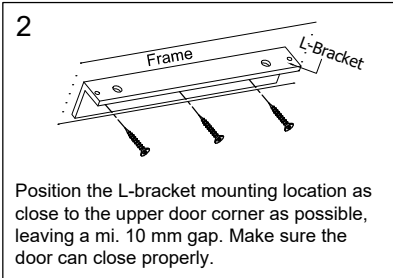
 - 300ZL(L) = 39mm
 - 600ZL(L) = 46mm
 - 1200ZL(L) = 73mm
- 

2 Frame
L-Bracket

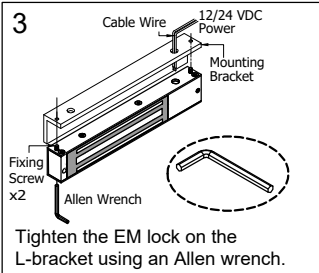
Position the L-bracket mounting location as close to the upper door corner as possible, leaving a min. 10 mm gap. Make sure the door can close properly.
- 

3 Cable Wire
12/24 VDC Power
Mounting Bracket
Fixing Screw x2
Allen Wrench

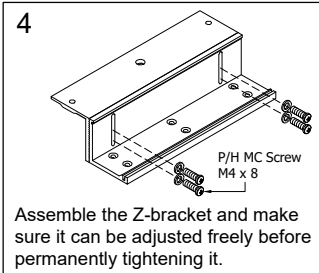
Tighten the EM lock on the L-bracket using an Allen wrench.
- 

4 P/H MC Screw M4 x 8

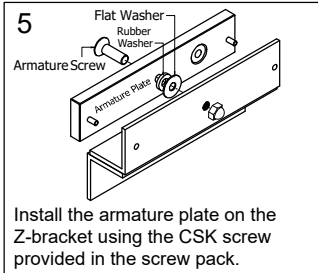
Assemble the Z-bracket and make sure it can be adjusted freely before permanently tightening it.
- 

5 Flat Washer
Rubber Washer
Armature Screw
Armature Plate

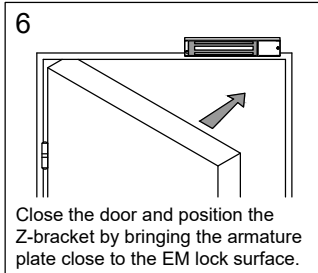
Install the armature plate on the Z-bracket using the CSK screw provided in the screw pack.
- 

6

Close the door and position the Z-bracket by bringing the armature plate close to the EM lock surface.

Need assistance? Contact Us: 1-800-340-0727 // support@visionistech.com // www.visionistech.com

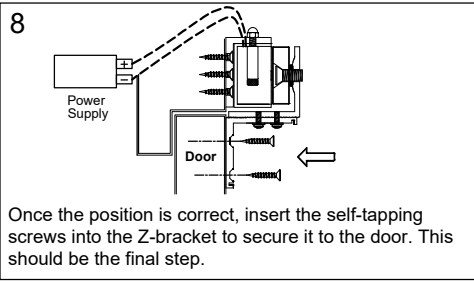
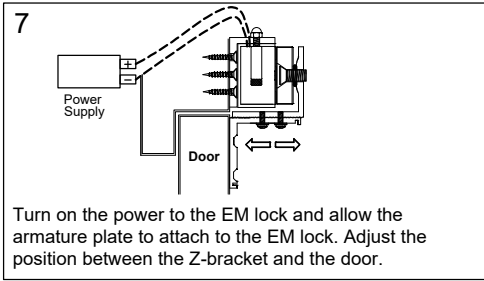

Distance in feet from the power supply to the furthest lock unit

	Amps	25f	50f	75f	100f	150f	200f	250f	300f	400f	500f	1000f
	0.25	18	18	18	18	18	16	16	14	14	12	
Minimum	0.50	18	18	18	16	16	14	12				
Wire Gauge	0.75	18	18	16	14	12	12					
for 12VDC	1.00	18	16	14	14	12						
	1.50	18	14	12	12							
	2.00	16	14	12								

	Amps	25f	50f	75f	100f	150f	200f	250f	300f	400f	500f	1000f
	0.25	18	18	18	18	18	18	18	18	16	16	16
Minimum	0.50	18	18	18	18	18	16	16	14	14	12	
Wire Gauge	0.75	18	18	18	18	16	14	14	12	12		
for 24VDC	1.00	18	18	16	16	14	14	12	12			
	1.50	18	18	16	14	14	12					
	2.00	16	16	14	14	12						

Need assistance? Contact Us: 1-800-340-0727 // support@visionistech.com // www.visionistech.com

LED Indicator Staying Red and Not Turning Green

If the LED indicator remains red and does not turn green, the most common cause is that the armature plate is not properly aligned with the magnet, or the armature plate is mounted too rigidly.

LED Color Status

Green = Locked
Off = Open
Red = Unlocked

How to Fix It?

Check Magnet Installation

Ensure the magnet body is securely mounted on the door frame. The magnet must be fully aligned and make proper contact with the armature plate.

Check for Gaps

Make sure there are no gaps between the magnet and the armature plate when the door is closed.

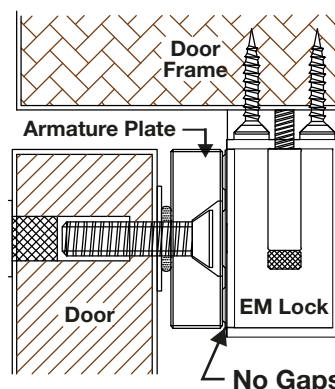

Verify Bracket Alignment

Determine whether L or Z brackets are required to correctly align the armature plate with the magnet.

Adjust Armature Plate Tightness

Loosen the armature plate's tightening screw slightly. The armature plate should not be mounted too rigidly; a small amount of movement (slight play) is normal and helps ensure proper contact.

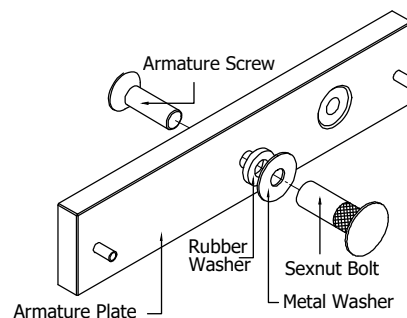

Questions	Cause of problem	Solution
Lock does not close	<ol style="list-style-type: none"> 1. Power cables are too thin or too long from the power source. 2. No power supply. 3. Incorrect wiring. 	<ol style="list-style-type: none"> 1. Use thicker power cables. 2. Repair or replace the power supply. 3. Correct the wiring.
Weak closing force	<ol style="list-style-type: none"> 1. The armature plate is not properly aligned with the lock. 2. Incorrect armature plate installation. 3. Debris or objects between the lock and the armature plate. 4. Faulty power supply. 5. The lock is damaged. 	<ol style="list-style-type: none"> 1. Adjust the alignment of the lock and armature plate. 2. Adjust the screw and rubber washer. 3. Clean the lock and armature plate. 4. Repair the power supply. 5. Replace the lock.
Lock does not open	The lock is constantly energized.	Check the wiring.

Need assistance? Contact Us: 1-800-340-0727 // support@visionistech.com // www.visionistech.com