

This product is discontinued



Features

- Face plate:
160Lx25Wx31H (mm) - 6.30Lx0.98Wx1.22H (in.)
- Voltage: 12VDC
- Current: 200mA
- Feature: Fail safe (NC)
- Signal Output: NO/NC/COM
- Glass Thickness: 12-15mm (0.47 – 0.5in.)
- Weight: 0.42kg (0.92 pounds)

Dimensions

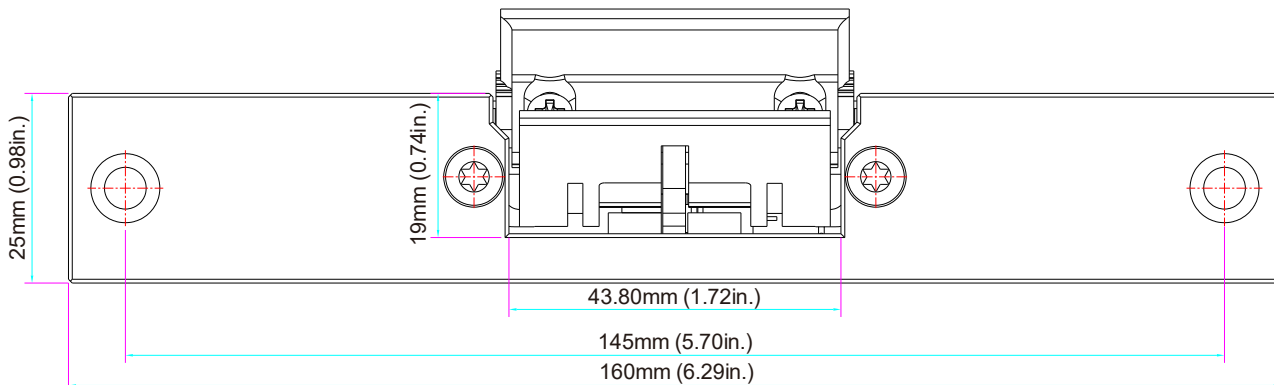
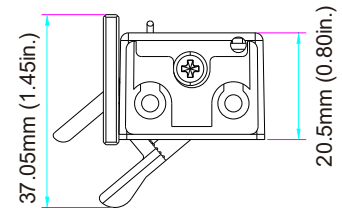
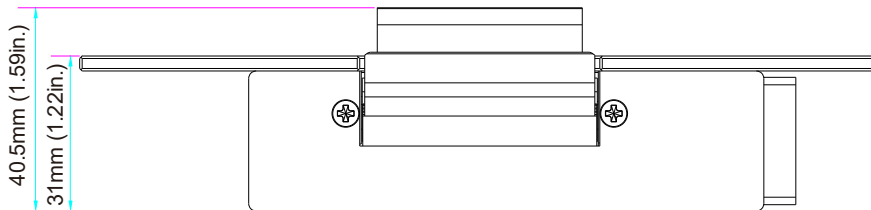

Disclaimer: VISIONIS reserve the right to go ahead with any modifications of models or features or price without forewarning. All the information and specifications stated in this document are current at the time of publication. Attention: We are not responsible for the improper installation of this kit. If you are not handy with electrical equipment you should contact a professional electrician. You will also need to check with your local Fire authority to see if you need anything else to comply with local Fire Codes. We are not responsible for any damage or fees that can occur.



sales@visionistech.com



www.visionistech.com