

Double Door Magnetic Lock With LED Status Sensor (600lbsx2)

REF.
VIS-600D-LED



The VISIONIS VIS-600D-LED is designed to keep your double doors secure with a 600 lbs holding force per door (1,200 lbs total).

Whether you're securing a retail store, office, or commercial building, this lock provides strong and reliable protection, preventing unauthorized access with a firm electromagnetic hold.

Features

- Ideal for double swing doors
- Dual voltage selectable (12 VDC or 24 VDC)
- Low current consumption
- Reliable holding force
- Hall effect sensor monitoring output
- Green/Red LED indication for EM lock status
- Durable and silence operation
- Cosmeticized anodized aluminum casing
- Surge & spike protection PCB
- Anti-tamper jam nuts
- Anti residual magnetism kick off button

Model No.	VIS-600D-LED
Usage Environment	Indoor only
Input Voltage	DC 12V / 24V
Input Current	12V 510 mA ×2 (±5%) ; 24V 285 mA ×2 (±5%)
Hall Effect Contact	SPDT, rated 1 A @ 24 VDC
Function	Fail Safe (Normally Close) = Unlocked when the power is OFF
Holding Force	Up to 600 lbs x 2 (272 kg x 2)
Product Dimensions	Armature - 180L x 38W x 11H mm - (7.08L x 1.50W x 0.43H in) Magnet - 500L x 42W x 25H mm - (19.68L x 1.65W x 0.98H in)
Weight	Magnet: 3.8 kg (±1%) - 8.37 lbs
Anti-Rust Surface Treatment	Blue Zinc Plating
Operating Temperature	0 °C ~ 55 °C (32 °F ~ 131 °F)
Operating Humidity	0 ~ 95% (non condensing)
Certifications & Compliance	CE
Suitable For	Wooden door, glass door, metal door, fireproof door

Need assistance? Contact Us: 1-800-340-0727 // support@visionistech.com // www.visionistech.com

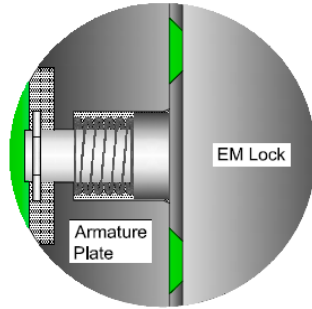

EM Lock Energized

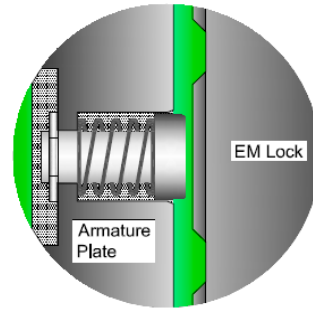

EM Lock De-energized

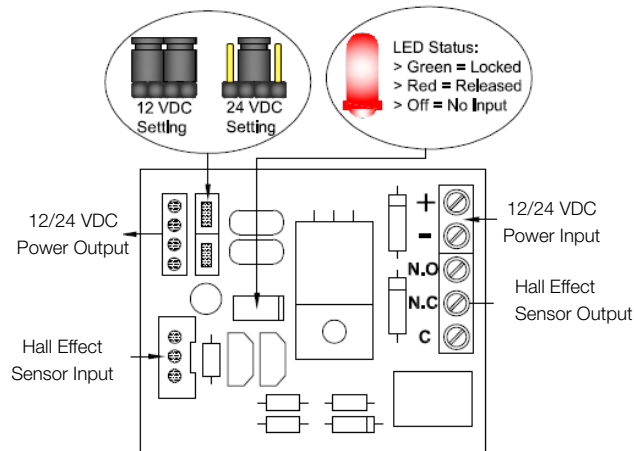

IMPORTANT!

Set the jumper position according to the power input before switching on the power.